

Libretto d'istruzioni
Instruction booklet
Notice d'emploi et d'entretien
Betriebsanleitung
Manual de instrucciones
Manual de instruções
Instruktionshäfte
Instrukcja

Használati utasítás
Uživatelská příručka
Manual de instruțiuni
Upute za uporabu
Kullanım kılavuzu
Εγχειρίδιο οδηγιών
Инструкции по эксплуатации
说明手册

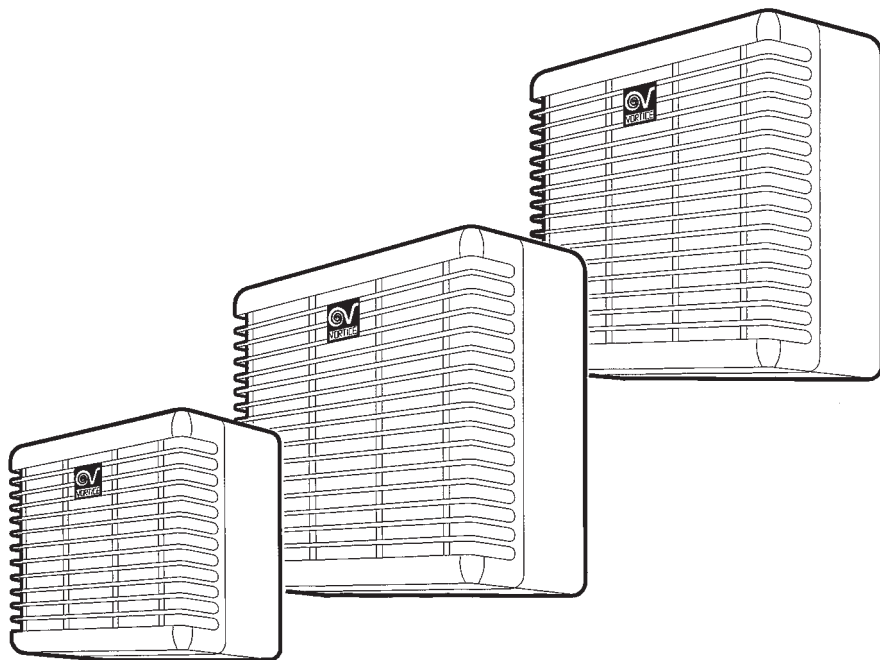

VORT PRESS 110 LL - 140 LL - 220 LL
VORT PRESS 110 T LL - 140 T LL - 220 T LL



MADE IN ITALY COD. 5.371.084.882

18/11/2011

VORTICE LIMITED
Beeches House - Eastern Avenue
Burton on Trent
DE13 0BB
Tel. (+44) 1283-492949
Fax (+44) 1283-544121
UNITED KINGDOM

VORTICE FRANCE
72 Rue Baratte-Cholet
94106 Saint Maur Cedex
Tel. (+33) 1-55.12.50.00
Fax (+33) 1-55.12.50.01
FRANCE

VORTICE ELETTROSOCIALI S.p.A.
Strada Cerca, 2 - frazione di Zoate
20067 TRIBIANO (MI)
Tel. (+39) 02-90.69.91
Fax (+39) 02-90.64.625
ITALIA

Attenzione: Seguire assolutamente questi schemi per evitare problemi al motore.

Warning! Always refer to the diagrams to prevent motor operating problems.

Attention! Respecter scrupuleusement ces schémas pour éviter tout problème au moteur.

Achtung! Bei der Installation unbedingt diese Anleitung befolgen, um Schäden am Motor zu vermeiden.

Atención! Respetar los esquemas, en caso contrario el motor podría dañarse.

Atenção! Siga à risca estes esquemas para evitar problemas no motor

Observera! Följ ovillkorligen dessa scheman för att undvika problem med motorn.

Uwaga! Bezwzględnie należy przestrzegać niniejszych zaleceń, aby uniknąć problemów z silnikiem

Figyelem! Pontosan kövessük a bekötési rajzokat, hogy a motorral kapcsolatban ne legyenek problémák.

Upozornění! Dodržujte přesně tato schémata, jinak dojde k poruchám motoru.

Atenție! Respectați în mod obligatoriu aceste scheme pentru a evita problemele la motor.

Oppez! Obvezno slijedite ove sheme kako biste izbjegli probleme na motoru.

Dikkat! Motorla ilgili sorunların çıkmasını önlemek için bu talimatlara kesinlikle riayet ediniz

Προσοχή! Τηρήστε πιστά αυτά τα σχέδια για να αποφύγετε προβλήματα στο motor

Внимание! Во избежание проблем с двигателем обязательно соблюдать приведенные схемы.

注意! 请严格遵守这些电路图的说明, 以避免电机出现问题。

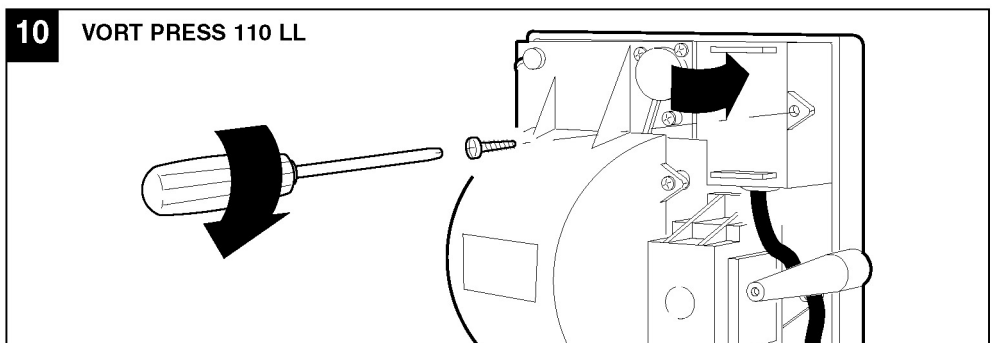
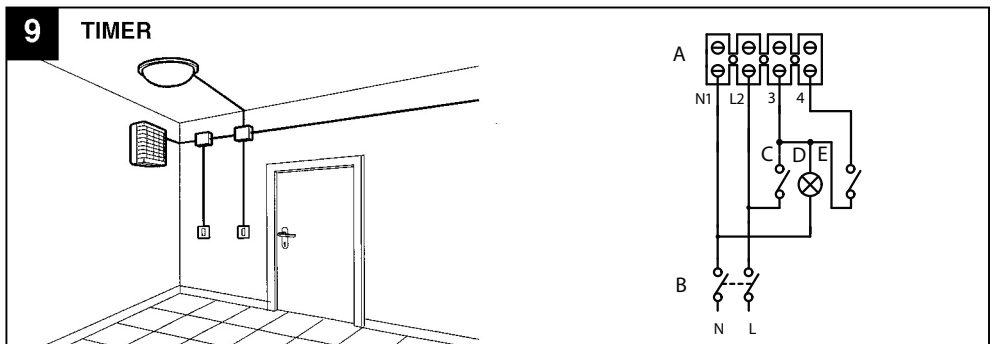
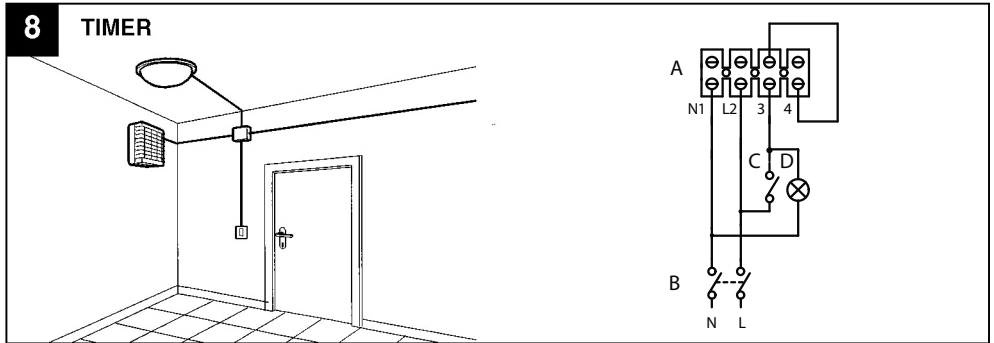

UTILIZZO

OPERATION
UTILISATION
ANWENDUNG
UTILIZACI3N
UTILIZAÇ3O
ANVÄNDNING
UŽYCIÉ
FELHASZNÁLÁS

POUŽITÍ
UTILIZARE
KORIŠTENJE
KULLANMA (İŞLETİM)
ΧΡΗΣΗ
ЭКСПЛУАТАЦИЯ
使用須知

